



fives

CINCINNATI VIKING

Compact Centerless Grinder

CINCINNATI VIKING



Compact centerless grinder

For the grinding process of all kinds of bars, tubes, cam shafts, gear shafts and rollers in either through-feed or plunge cut working method

- Best in class 3,000,000+ lb/in. of static stiffness machine base
- CNC controlled motors & electric devices
- Siemens, Fanuc & Allen-Bradley controls offering
- Sub-micron control resolution 0.1 micron



CINCINNATI VIKING

Rigid Machine Design

With the ability to grind to very tight tolerances, the Cincinnati Viking and RK grinders negate the need for multiple grind passes. Long, round bars can also be ground from beginning to the very end with the same tolerance. This helps eliminate waste and, ultimately, saves you time and money.

High stiffness also enables these machines to achieve compensation adjustments of 0.001 mm. This level of precision means less wheel wear and a much better surface finish.

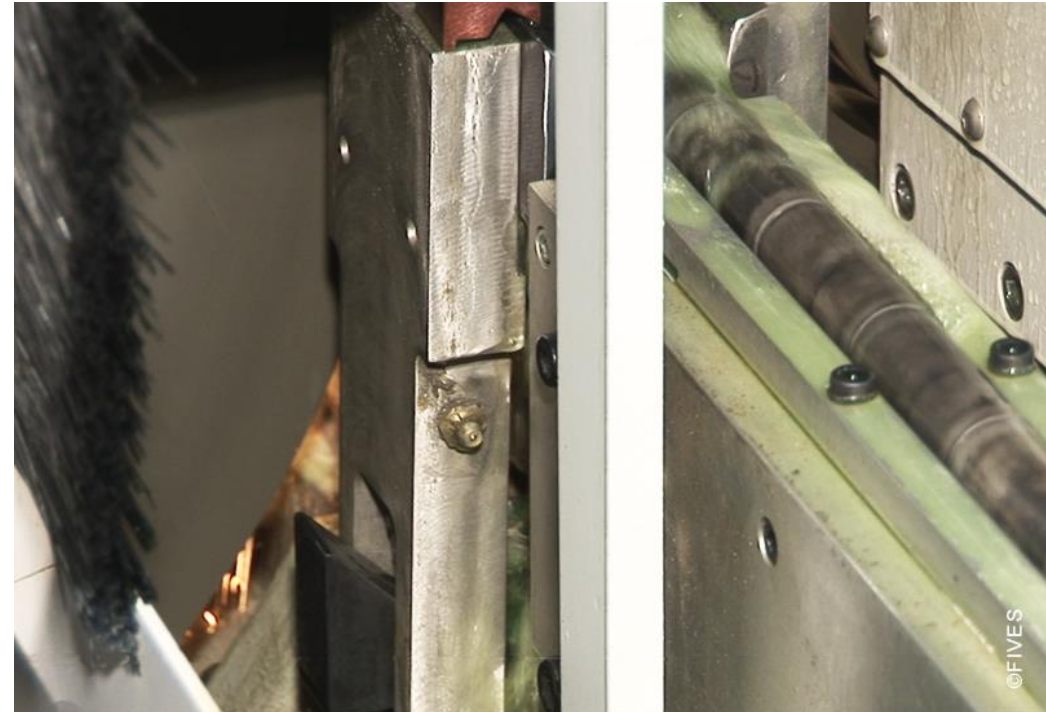

CINCINNATI VIKING

A complete, automated solution

We can provide the expertise and the automation to make your process and operation as easy as possible. We offer turnkey solutions that include all of the components you will need for your grinding operation, including infeed / outfeed system and gauging system.

The Cincinnati Viking and RK can be integrated into new and existing product lines and is compatible with a number of different control systems, including Landis 6400, Allen Bradley, Siemens and Fanuc.

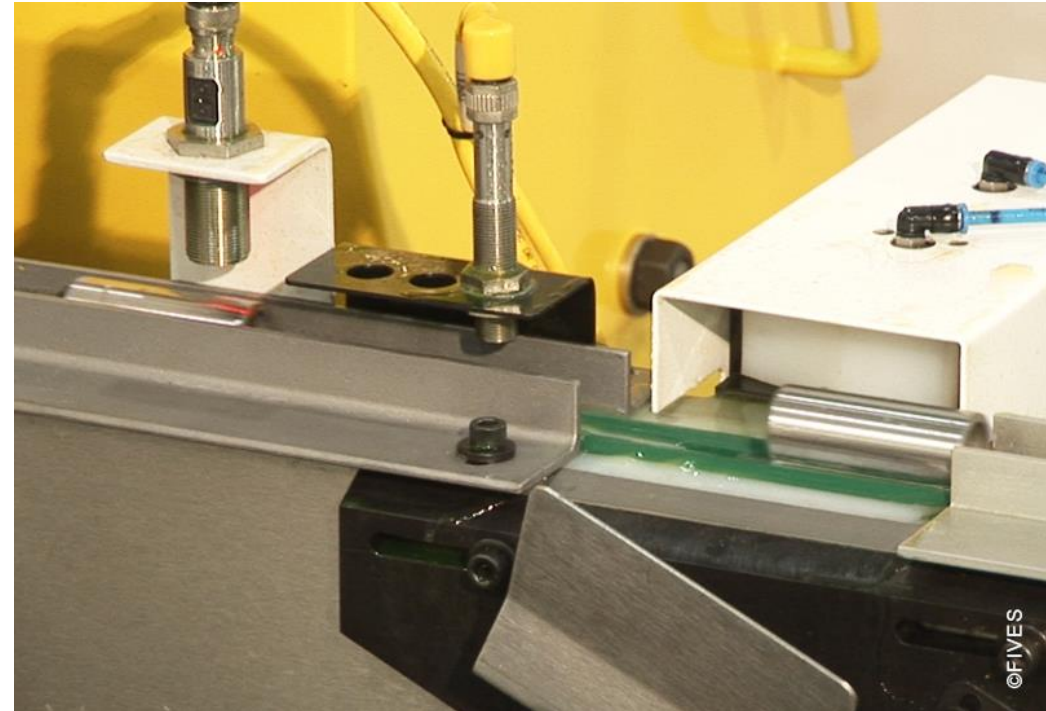

CINCINNATI VIKING

Grind a wide variety of materials

The high rigidity of the Cincinnati Viking and RK centerless grinding machines means they can use super-abrasive (CBM) as well as conventional wheels. This opens up the possibility to grind a wider variety of materials, including stainless steel, inconel and titanium.

In addition, these machines are ideal for the grinding of high precision parts used in the medical and aerospace industries, as well as parts for the automotive, agricultural, appliance, power tools and fluid power sectors.



Additional key machine features include:

- 0.001 mm machine resolution
- Single screw swivel adjustment
- Arranged for plunge-feed or through-feed operation
- Anti-friction slide-way systems
- ‘Twin-Grip’, dual support anti-friction spindle bearings
- Thermally stable bed design
- Best-in-class, 3,000,000+ lb/in static stiffness
- Fast and easy set-up and wheel changeover



A peek under the hood

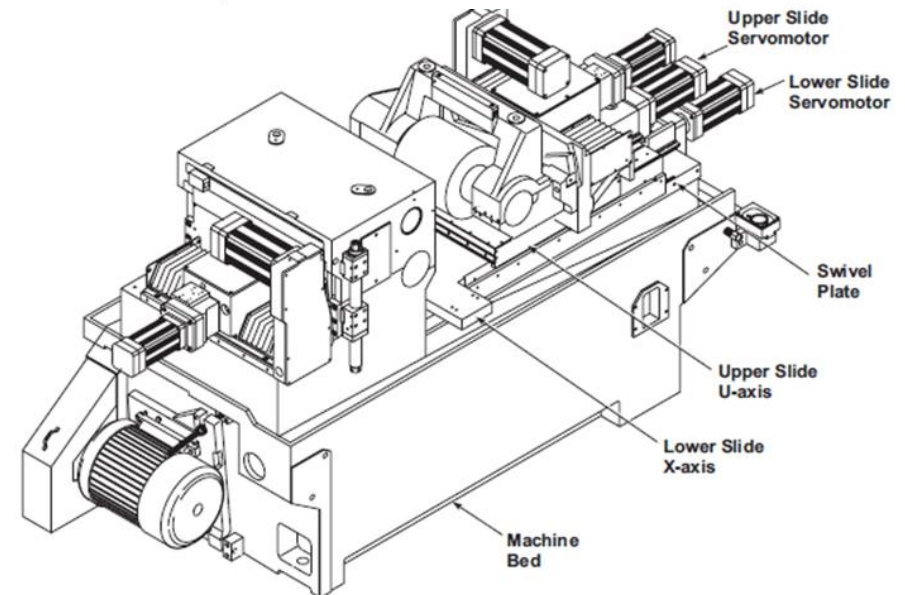
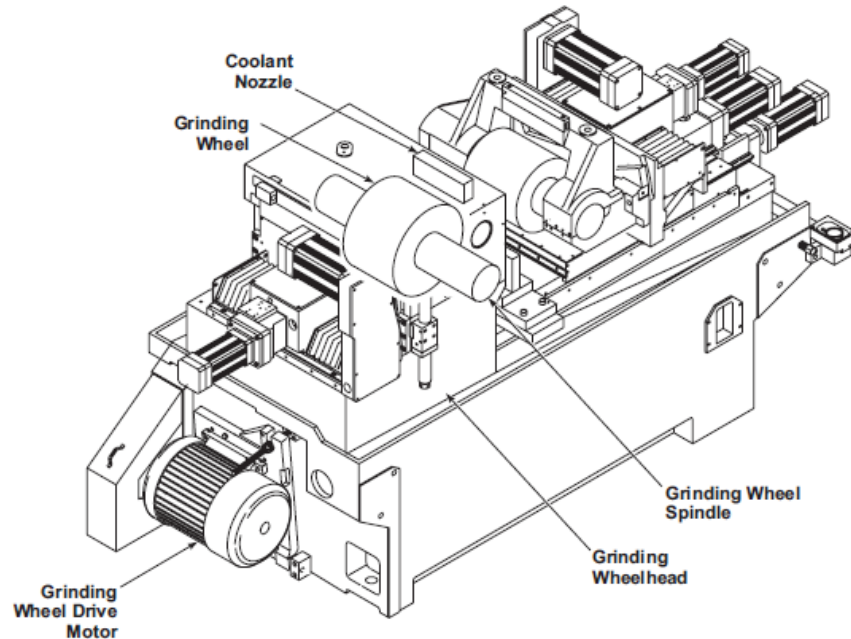
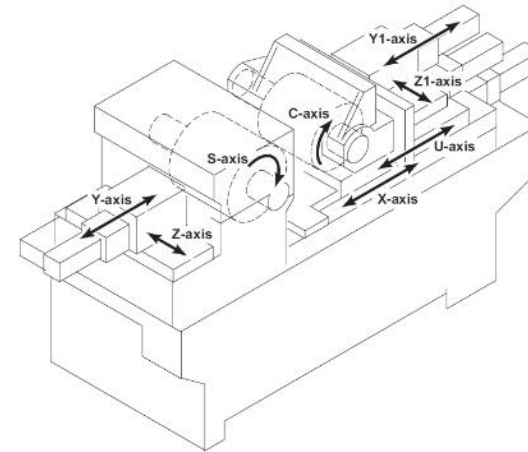
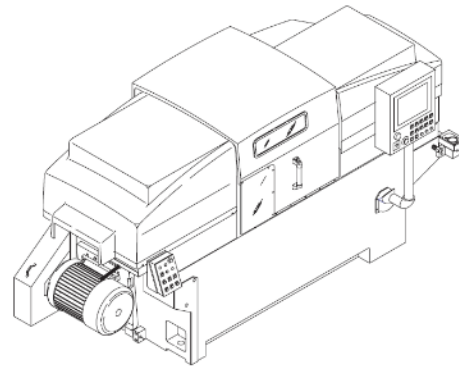

CINCINNATI VIKING



Specifications

Working capacity	
Min. / Max. outer diameter	1.2 - 60 mm (0.05" - 2.4")
Type	Twin grip
Grinding wheel	
Sizes / width	250 mm (9.8")
Max. / Min. OD	450 / 300 mm (17.7" / 11.8")
Motor power	15 / 30 kW*
Peripheral speed	45 (60) m/sec (148 ft/sec)
Regulating wheel	
Sizes / width	250 mm (9.8")
Max. / Min. OD	355 / 255 mm (14" / 10")
Motor power	3.3 kW
Operating speed	10 - 600 rpm

Infeeds	
Max. plunge infeed	1,500 mm/min (4.9 ft/min)
Min. plunge infeed	0.1 mm/min (0.004 in/min)
Dimensions	
Dimensions (W x D x H)	3,100 x 2,700 x 2,300 mm (10.2' x 8.9' x 7.6')
Machine weight	9,072 kg (20,000 lb)

CINCINNATI VIKING/RK



Specifications

	Cincinnati Viking	Cincinnati RK
Working capacity		
Min. / Max. outer diameter	1.2 - 60 mm (0.05" - 2.4")	12.7 - 152 mm (0.5" - 6")
Type	Twin grip	Twin grip
Grinding wheel		
Sizes / width	250 mm (9.8")	508 mm (20")
Max. / Min. OD	450 / 300 mm (17.7" / 11.8")	610 / 431 mm (24 " / 17")
Motor power	15 / 30 kW*	37 / 55 kW*
Peripheral speed	45 (60) m/sec (148 ft/sec)	45 (60) m/sec (148 ft/sec)
Regulating wheel		
Sizes / width	250 mm (9.8")	508 mm (20")
Max. / Min. OD	355 / 255 mm (14" / 10")	355 / 279 mm (14" / 11")
Motor power	3.3 kW	3.3 kW
Operating speed	10 - 600 rpm	10 - 300 rpm

CINCINNATI VIKING/RK



Specifications

	Cincinnati Viking	Cincinnati RK
Infeeds		
Max. plunge infeed	1,500 mm/min (4.9 ft/min)	1,500 mm/min (4.9 ft/min)
Min. plunge infeed	0.1 mm/min (0.004 in/min)	0.1 mm/min (0.004 in/min)
Dimensions		
Dimensions (W x D x H)	3,100 x 2,700 x 2,300 mm (10.2' x 8.9' x 7.6')	3,300 x 2,800 x 2,700 mm (10.8' x 9.2' x 8.9')
Machine weight	9,072 kg (20,000 lb)	11,794 kg (26,000 lb)